

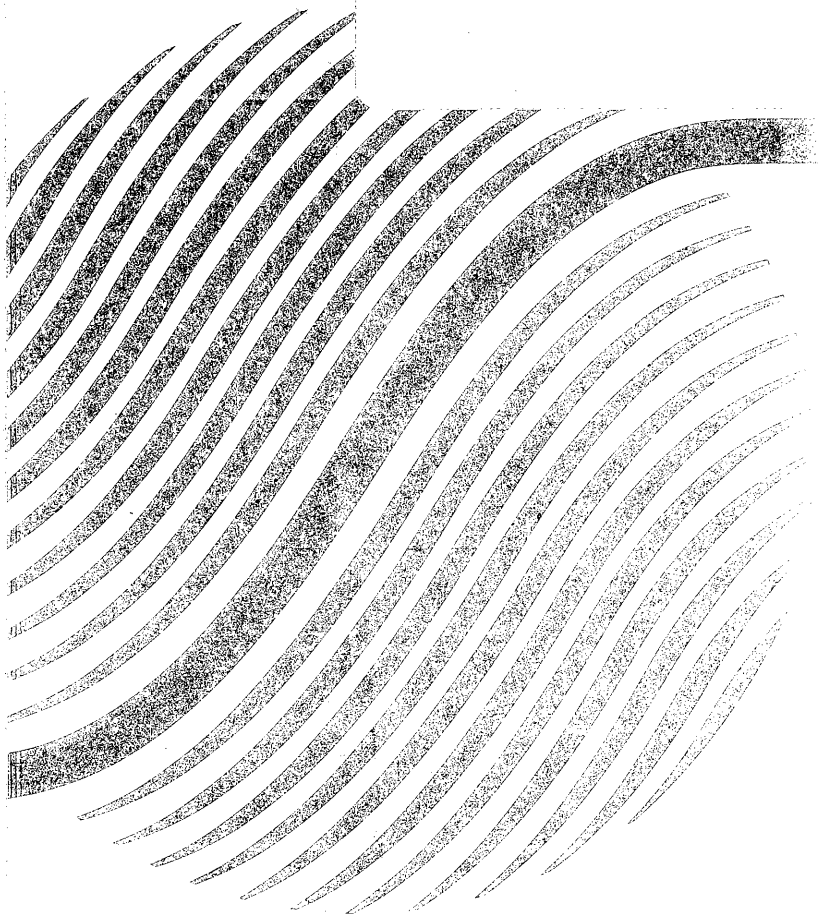

# Shell Research

Magazine



... ..

... ..

KSLA Rapporten Bibliotheek

**100185/4**



**ARGR.92.091**

Project PL5101 Code 406.70.151 (2P99)

(Chemicals)

**A scouting investigation of phase changes in Carilon E  
and EP using hot-wire microscopy**

by

C.H.J.B. van Gaans



**CONFIDENTIAL**

Copyright is vested in Shell Internationale Research  
Maatschappij BV, The Hague.

This is a CONFIDENTIAL document. Any distribution beyond the  
parties listed within must be authorised by Shell Internationale  
Research Maatschappij BV. Reference to this document should be  
made only in CONFIDENTIAL documents.

Neither the whole nor any part of this document may be reproduced,  
stored in any retrieval system or transmitted in any form or by any  
means (electronic, mechanical, reprographic, recording or otherwise)  
without prior written consent of the copyright owner.

**Billiton Research Arnhem**

**ARGR.92.091**

Project PL5101 Code 406.70.151 (2P99)

(Chemicals)

**A scouting investigation of phase changes in Carilon E  
and EP using hot-wire microscopy**

by

C.H.J.B. van Gaans

Co-worker: N. Teunissen

Approved by: V.G. Aurich

Keywords: Carilon, Hot-wire microscope, phase changes, spherulites.

### **Executive Summary**

At the request of CRCSL the potential of high temperature microscopy for studying the melting and crystallisation behaviour of E-type and EP-type Carilon was investigated by carrying out a small series of scouting experiments. The results of this investigation show that high temperature microscopy is excellently suitable for observing phase changes in Carilon. Melting and crystallisation phenomena were observed in great detail owing to contrast enhancement of the microscopical image (using coloration). In both E- and EP type Carilon at least two stages of melting could be observed. The first stage concerns melting of the matrix and the second stage melting of spherulites. In E-type melting of the matrix also proceeds in two stages. On the basis of the data provided the kinetics of melting and crystallisation can be assessed. Differences in microstructure and in the melting and crystallisation behaviour between E- and EP-type Carilon were observed. EP-type consists of a higher concentration of spherulites and melts at a lower temperature than E-type and also shows contraction and folding of microtomed specimen during melting whereas E-type specimen remains rigid and undeformed during melting.

A follow-up program is proposed during which a comparison is made between Carilon and two other polymers (polypropylene and polyacetal) to ensure that the phenomena observed during the scouting study are not artefacts related to the microscopical technique used but are real phase changes. Subsequently melting and crystallisation of Carilon will be investigated systematically by varying all experimental parameters to derive a fundamental understanding of the phase changes in Carilon. Included in this fundamental study will be an investigation of the effects of cross-linking and degradation of Carilon in air.

**Arnhem, August 1992**

**ARGR.92.091**

Project PL5101 Code 406.70.151 (2P99)

(Chemicals)

**A scouting investigation of phase changes in Carilon E  
and EP using hot-wire microscopy**

by

C.H.J.B. van Gaans

Co-worker: N. Teunissen

Approved by: V.G. Aurich

Keywords: Carilon, Hot-wire microscope, phase changes, spherulites.

### **Technical Summary**

At the request of CRCSL the potential of high temperature microscopy for studying the melting and crystallisation behaviour of E-type and EP-type Carilon was investigated by carrying out a small series of scouting experiments. The results of this investigation show that high temperature microscopy is excellently suitable for observing phase changes in Carilon. Melting and crystallisation phenomena were observed in great detail owing to contrast enhancement of the microscopical image (using coloration).

E-type Carilon melts in three stages, the first two comprise melting of the matrix at 242 °C and 256 °C, respectively. The third stage involves melting of spherulites. This result is notable in view of results of DSC measurements which indicate only one stage of melting. Melting was observed to take place very rapidly. During cooling the crystallisation stages were observed to take place in the reversed order (though at a much slower rate) as the melting stages, hereby restoring the original texture.

The microstructure of EP-type Carilon differs from that of E-type. EP-type consist of a higher concentration of spherulites and contains deformation bands and remnant microstructures after injection moulding. EP-type melts at lower temperatures than E-type and showed, in contrast to E-type, contraction and folding of the microtomed specimen above the melting point. In one experiment melting in two stages was observed, in another experiment only a single melting stage (this result is notable in view of DSC data which indicate two-stage melting). During cooling crystallisation of individual spherulites was observed and progression of crystallisation monitored. Crystallisation continued down to room temperature during which the original microstructure was restored (including deformation bands).

A follow-up program consisting of two stages is proposed during which melting and crystallisation of Carilon will be studied systematically to derive a fundamental understanding of phase changes in Carilon. The effects of cross-linking and degradation of Carilon in air will also be included in this study.

**Arnhem, August 1992**

## Contents

	Page
1. Introduction	1
2. Experimental	1
3. Theory and importance of Coloration of polarised light images of Carilon by using compensator plates	2
4. Results of high temperature microscopy	3
5. Suggestions for future work	5
Figure 1 Schematic outlines of hot-wire thermocouple	6
Figure 2 DSC melting curve of E-type Carilon	7
Figure 3 DSC melting curve of EP-type Carilon	8
Figure 4 Typical photo micrographs of Carilon E-EP-types	9
Figure 5 Video images of the melting behaviour of E-type Carilon	10
Figure 6 Video images of melting and crystallisation of E-type Carilon	11
Figure 7 Video images of melting of EP-type Carilon	12
Figure 8 Video images of crystallisation of EP-type Carilon	13
Figure 9 Video images of crystallisation of EP-type Carilon in close-up	14
Figure 10 Rheology of microtomised sections of E- and EP-type Carilon above the melting point	16

## 1. Introduction

Phase changes in polymers can be characterised by measuring heat effects using Differential Scanning Calorimetry (DSC) and changes in strength by Dynamic Mechanical Thermal Analysis (DMTA). It was recognised by CRCSL that high temperature microscopy could probably contribute to a fundamental understanding of the thermal behaviour of Carilon by direct observation of melting and crystallisation phenomena. BRA was identified as the Shell laboratory with extensive expertise in this field. At CRCSL's request BRA carried out a limited number of experiments which were aimed to investigate the potential of high temperature microscopy for this purpose. In this report the results of these experiments are presented.

## 2. Experimental

Two high temperature microscopy techniques were tested, i.e. a hot-stage and a hot-wire technique. The hot-stage microscope is suitable for observing surface phenomena in polarised reflected light. Two experiments with the hot-stage showed that this technique is not suitable for studying the thermal behaviour of Carilon. The hot-wire microscope (HWM) is a normal polarised light microscope fitted with a U-shaped thermocouple which acts both as a heating source and as a temperature probe. The schematic outlines of the thermocouple are shown in Figure 1. The HWM allows observation of specimen in transmitted light and permits, owing to the fact that specimen are placed on the welding point of the thermocouple, accurate temperature measurement of the phenomena observed. Microtomed sections of E- and EP-type Carilon were examined in polarised transmitted light to obtain an impression of the microstructure of the polymer and, after this examination, sectioned further to obtain a representative specimen suitable for the HWM. Colour was added to the microscopical image by using compensator plates. The theory behind the use of these plates is outlined in Section 3. Each experiment consisted of a heating and a cooling cycle and was recorded on video tape. In total six experiments were carried out in this manner. The heating rate used during the first experiment was 10 °C/min. The heating rate used during the other five experiments was 5 °C/min. The atmosphere in the HWM heating chamber was dry argon.

For comparison with the hot-wire microscopy experiments, E- and EP-type Carilon samples were analysed with a DSC to determine melting and crystallisation temperatures. The atmosphere in the DSC consisted of argon. The heating rate was 5 °C/min. Typical melting curves are illustrated in Figures 2 and 3. The results of DSC measurements are:

- E-type:** Melting proceeds mainly in one stage. The onset is at about 240 °C. The shape of the melting endotherm shows a deflection at 252 °C which suggests that the melting process does not proceed at a constant rate. The crystallisation curve shows a sharp peak with an onset at 228 °C and end at 210 °C. The enthalpy of crystallisation is almost similar to the enthalpy of fusion which indicates that crystallisation is practically completed at about 210 °C.
- EP-type:** Melting proceeds in two stages. The first extrapolated onset of melting is at 210 °C, the second onset is at 220 °C. Only a small and broad crystallisation peak was identified with an onset at 160 °C and end at 110 °C. The enthalpy of crystallisation is much smaller than the enthalpy of fusion which indicates that only part of the material actually crystallises. The heat of fusion of E-type Carilon is 1.5 times larger than that of EP-type.

### 3. Theory and importance of coloration of polarised light images of Carilon by using compensator plates

Plane polarised light travelling through a transparent medium which has a crystalline or otherwise ordered molecular structure proceeds at different speeds depending on the orientation of the crystal structure or molecular ordering. Along an orientation A in a transparent medium the speed of light  $C_A$  is given by:

$$C_A = \frac{C_v}{n_A} \quad (1)$$

$n_A$  is the refractive index of the material in direction A  
 $C_v$  is the speed of light in vacuum

For an orientation B perpendicular to direction A the speed of light will be larger or smaller, hence the refractive index  $n_B$  will be different from  $n_A$ . This implies that, depending on the structure and thickness of the material, a phase difference  $s$  exists between light travelled along direction A and light travelled along direction B. The magnitude of  $s$  depends on the orientation of the sectioned surface relative to that of the crystal structure. The maximum phase difference  $\Sigma$ , which is called the birefringence, is obtained when  $n_A$  and  $n_B$  are parallel to the sectioned surface, hence when the difference between the two refractive indices is largest:

$$\Sigma = n_B - n_A \quad (2)$$

Through the polarised light microscope birefringent materials with a constant thickness of typically 20  $\mu\text{m}$  appear as greyish coloured when the birefringence is low, bright red, blue or yellow coloured when birefringence is intermediate, and pastel coloured when birefringence is high. Amorphous materials are characterised by a unique refractive index and are therefore not birefringent. When amorphous materials are observed through a microscope with crossed polarisation filters the incident polarised light is completely blocked by the analyser filter.

Microtomed sections of Carilon with a typical thickness of 16  $\mu\text{m}$  show, through a polarised light microscope using crossed polarisation filters, greyish colours which indicate that the polymer has a crystalline structure with a low birefringence. Subsequent stages during phase changes, which in theory could be seen as slight changes in shades of grey, are probably not identified as such because the human eye is not very sensitive to slight changes in shades of grey. By contrast, the human eye is particularly sensitive to slight changes in bright colours. For this reason, the microscopical image of Carilon was colorated by optical means to obtain bright, so-called first-order, colours. Coloration was achieved by inserting an anisotropic medium (a compensator) into the light path in-between the polariser and analyser filters such that the birefringence of this medium is added to that of Carilon. By careful selection of the type of compensator the total anisotropy (i.e. the sum of the birefringence of Carilon plus that of the compensator) produces first order interference colours. The type of compensator used produces a first order red which - by the human eye - is seen as purplish-red. This implies that the colour of the image of amorphous parts of Carilon, for instance after melting, is purplish-red. The birefringence of crystalline and molecularly ordered parts of Carilon is such that images with bright yellow and blue colours are produced. Slight changes in the molecular structure during melting or crystallisation can now be observed by changes in these colours.

#### 4. Results of high temperature microscopy

Prior to hot-wire microscopy the E- and EP type Carilon were examined with a normal polarised light microscope fitted with a compensator plate. This examination showed that both polymers are inhomogeneous in structure.

Typical components identified in the Carilon microstructure are:

- (a) Spherulites: more or less isometric crystalline particles with a typical size of 3-4  $\mu\text{m}$  occurring dispersed in the polymer.
- (b) Matrix: polymer material in-between the spherulites also showing a molecular ordering.
- (c) Deformation bands: distinct zones with a typical thickness of 100 - 300  $\mu\text{m}$  which show so-called undulous extinction of the transmitted polarised light during rotation of the sample.
- (d) Skin: rim of the polymer sample, often showing severe deformation.
- (e) Relict structures: these are observed as folded strings of spherulites oriented according to the flow patterns which prevailed during injection moulding and which have been preserved in the polymer during solidification.

These components were observed in both E and EP Carilon. Despite this, some differences were observed between the two types. EP-type Carilon contains a much higher concentration of spherulites than E-type. Relict structures are more conspicuous in EP-type than in E-type. Fine striations, which probably were formed during microtommisation, are more distinctly present in E-than in EP-type. Typical examples of the microstructure of E- and EP-type Carilon are illustrated in Figure 4.

##### *E-type Carilon:*

Figure 5 shows four photomicrographs illustrating a typical sequence from room temperature to the melting temperature. The four photomicrographs were taken at the same location. The magnification is 1000 times.

Photo 5[a] shows an image of the rim section. The orientation of fine striations caused by the sectioning procedure is more or less north-south. The yellow and blue colours are indicative of the crystalline nature of the polymer. Differences in colour could either be caused by differences in thickness of the specimen caused by improper sectioning or by differences in crystal orientation (or molecular ordering). Dark spots are pores. Only a few spherulites (bluish spots) can be observed.

Photo 5[b] was taken after the electrical power had been switched on. The room temperature of 20 °C is now indicated in the upper-left part of the image. The difference between photo [a] and [b] is the occurrence of purplish-red bands on the left side and in the middle of photo [b]. The purplish-red colour of these bands indicate that the material has become amorphous (Note that the purplish-red colour implies that only the birefringence of the compensator plate is observed. Without the compensator plate the colour of these bands would have been black.) During discussion with CRCSL staff it was suggested that this sudden change in colour could be related to the glass transition in Carilon which takes place at about room temperature.

Melting of E-type takes place in two distinct stages. Photo 5[c] was taken shortly after the first stage of melting had taken place. The temperature of 254 °C is 12 °C above the onset of melting indicated by DSC measurement (see Section 5). This difference is probably related to the inaccuracy of the HWM B-type thermocouple at these low temperatures (see Section 5). As expected, melting was associated with a change in colour from yellow to purplish-red. Careful examination of the images showed that only part of the matrix melted. Other parts of the matrix did not melt nor did the spherulites melt because these parts of the microstructure did not show a change in colour.



Photo 5[d] illustrates the second stage of melting. The spherulites are, in this image, still faintly visible and apparently are not yet molten. The NNE-SSW orientation is also visible which suggests a significant rigidity of the molten material. After complete melting the specimen was quenched by turning of the power.

Figure 6 illustrates melting and crystallisation of a core section of E-type Carilon. Photo 6[a] was taken during the onset of melting during which the colours were observed to change from bluish-green to orange-red while purplish colours were observed also. Spherulites are not clearly visible in this image. The temperature of the onset of melting (242 °C) is in excellent agreement with that of DSC measurement. Photo 6[b] was taken after completion of the first stage of melting. The left part of the image shows an almost completely molten matrix whereas the right part represents still crystalline material. The latter part melts at 256 °C as is shown in photo 6[c]. Photo 6[d] shows how the microstructure is restored during crystallisation. Compared with the DSC data crystallisation commences visibly at much lower temperatures and at a much lower rate (though, again, temperature indication could be inaccurate using this type of thermocouple).

In conclusion, melting of E-type Carilon proceeds in three steps, two of which comprise melting of the matrix. The third step comprises melting of spherulites.

#### *EP-type Carilon:*

Melting and crystallisation phenomena observed at low magnification (60 times) are shown in Figures 7 and 8. Close-ups of this image (at a magnification of a 1000 times) showing crystallisation phenomena are presented in Figure 9.

Figure 7 shows the black outlines of the U-shaped thermocouple and the specimen positioned upon the thermocouple. A N-S orientation of the specimen is faintly visible. Melting starts at the "hot-side" of the thermocouple (see Figure 1), which in the image is seen in the centre of the lower limb of the thermocouple (Figure 7[a]), at 218 °C (the thermocouple is probably inaccurate at this low temperature). At 220 °C melting also starts at the opposite limb of the thermocouple and the molten area rapidly spreads in a N-S direction. Because the EP-specimen has curled up at the welding point of the thermocouple and at the opposite end of the specimen (which can be seen on the photos because these parts are out of focus) and therefore are not in direct contact with the thermocouple, melting in the E-W direction of the specimen proceeds very slowly. The melting process proceeds not at constant rate but in short periods of rapid progress alternated with longer periods which are static. Photos 7[a-c] show the propagation of the melting front. Note that in photo 7[c] most of the original orientation has disappeared and that the material has started to contract and fold. At 238 °C the EP-specimen is completely molten (see Figure 10[d]).

Figure 8 shows the crystallisation during cooling of the same specimen as the one illustrated in Figure 7. Photos 8[a] - [c] show crystallisation as an increase in yellow coloration. Though the kinetics of crystallisation are much more slower than that of melting, the various parts of the specimen crystallise in the reverse order as compared with melting. From these low magnification images no information is gathered with regard to the various stages of melting.

During a subsequent experiment studied at a high magnification of the microscope (1000 times) two stages of melting were observed. The first stage of melting takes place at 230 °C and involves melting of the matrix in-between the spherulites. The second stage of melting begins at 238 °C and proceeds more slowly than the first stage (again, the temperature measurement of the thermocouple is probably not very accurate).

Crystallisation proceeds slowly and almost continuously during cooling to room temperature (Figure 9). The photo sequence starts when Carilon is probably still completely molten at 237 °C. Nevertheless, Figure 9[a] shows faint bluish spots which suggest that remnants of spherulites are still present in the melt. Formation of individual spherulites begins at and progress of crystallisation can be monitored from 190 °C as can be seen in photo 9[b]. The time indicated in this photo (upper-left corner of the monitor) is 7.48 h. Photo 9[c] was taken

one minute later and shows the progression of the crystallisation front within this minute. Taking into account the cooling rate of 5 °C/min and assuming that the temperature gradient over the sample is 4 °C at most, then photos [b] and [c] can be used to derive the crystallisation kinetics. These photos also show that the matrix remains amorphous (i.e. purplish-red coloured) almost down to room temperature. Photos 9[d] and [e] show a similar sequence.

Photos 9[f] and 9[g] show crystallisation of a rim section of the specimen and illustrate the difference in spherulites size between the deformation band (blue zone running N-S) and the adjacent areas. Note that the deformation band persisted after solidification from the melting temperature. In a subsequent experiment the temperature was increased up to 40 °C above the melting point, but the deformation bands became visible again during solidification.

During a third experiment using EP-type Carilon it was observed that melting occurred in one stage only and proceeded very rapidly. Despite this crystallisation was again a slow process.

Figure 10 illustrates the difference in rheology between microtomed sections of E- and EP-type Carilon before and after melting. Photos 10[a] and [b], taken from different specimen, show that E-type Carilon remains rigid after melting. Surface structures and orientations remain visible even above the melting point. By contrast, photos 10[c] and [d] show a totally different behaviour of EP-type Carilon which contracts and folds and loses its surface structures during melting.

In conclusion, in contrast to the observation of melting in E-type Carilon, melting in EP-type is less unambiguously because in one experiment only one stage of melting was observed whereas in another experiment two stages were identified. Crystallisation was observed in great detail and the data presented here could be used for calculating crystallisation kinetics. Microstructures typical of significant deformation were reproduced after solidification from the molten state.

## 5. Suggestions for future work

In consultation with CRC SL staff a follow-up program is outlined below which will consist of two distinct stages.

During stage 1 a comparison in melting behaviour between Carilon and polypropylene and polyacetal will be made. Also the effects of cross-linking and degradation of the polymer will be evaluated. This part of the program will serve as a baseline for further research and is aimed to verify whether the observed phenomena are typical of real phase changes and are not artefacts caused by the microscopical technique used.

During stage 2 the melting and crystallisation behaviour Carilon will be studied systematically in order to derive a fundamental understanding of these phase changes. It is intended to study the effects of all individual process variables in a systematic experimental set-up.

Prior to commencing stage 1 and 2 some improvements will be carried out. Improvement concerns the microtoming technique which should produce, if possible, sections without striations and of constant thickness. Improvements are also necessary in using the hot-wire microscope. The thermocouple used during the scouting experiments was a B-type couple suitable for high temperatures. At low temperatures (< 300 °C) this thermocouple (Pt-Rh) is not sensitive and should be replaced by a thermocouple which is more sensitive at these temperatures.

Arnhem, August 1992

sg

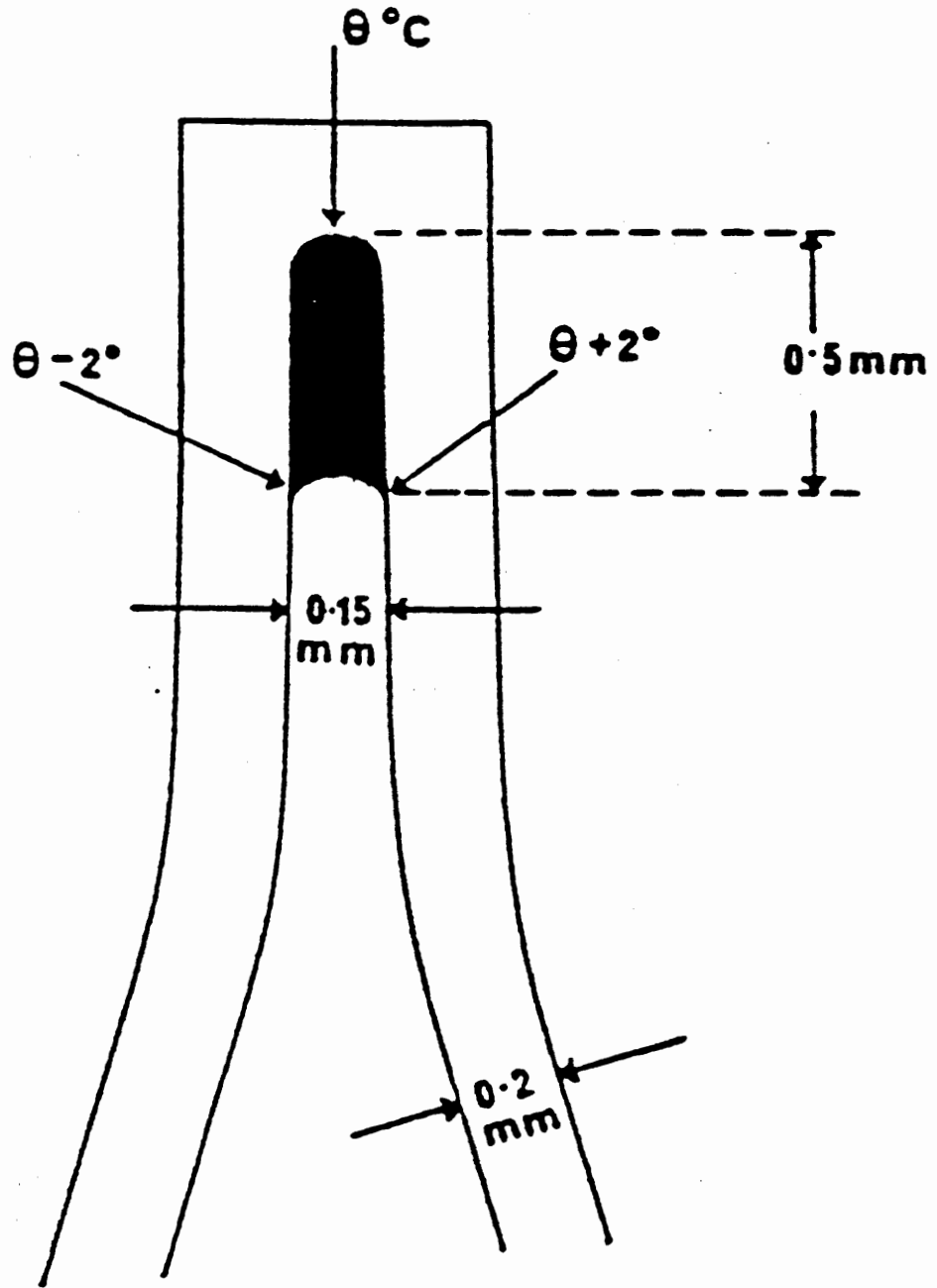

Figure 1 Schematic outliner of hot-wire thermocouple

DSC (PL)

Billiton Research BV

SAMPLE : Carilon  
RUN ID : 06.05.92  
SIZE : 21.760 mg  
OPERATOR: C. van Gaans

DATE RUN: May/06/1992  
GAS 1 : N2  
GAS 2 :  
COMMENT : E-type Run-2

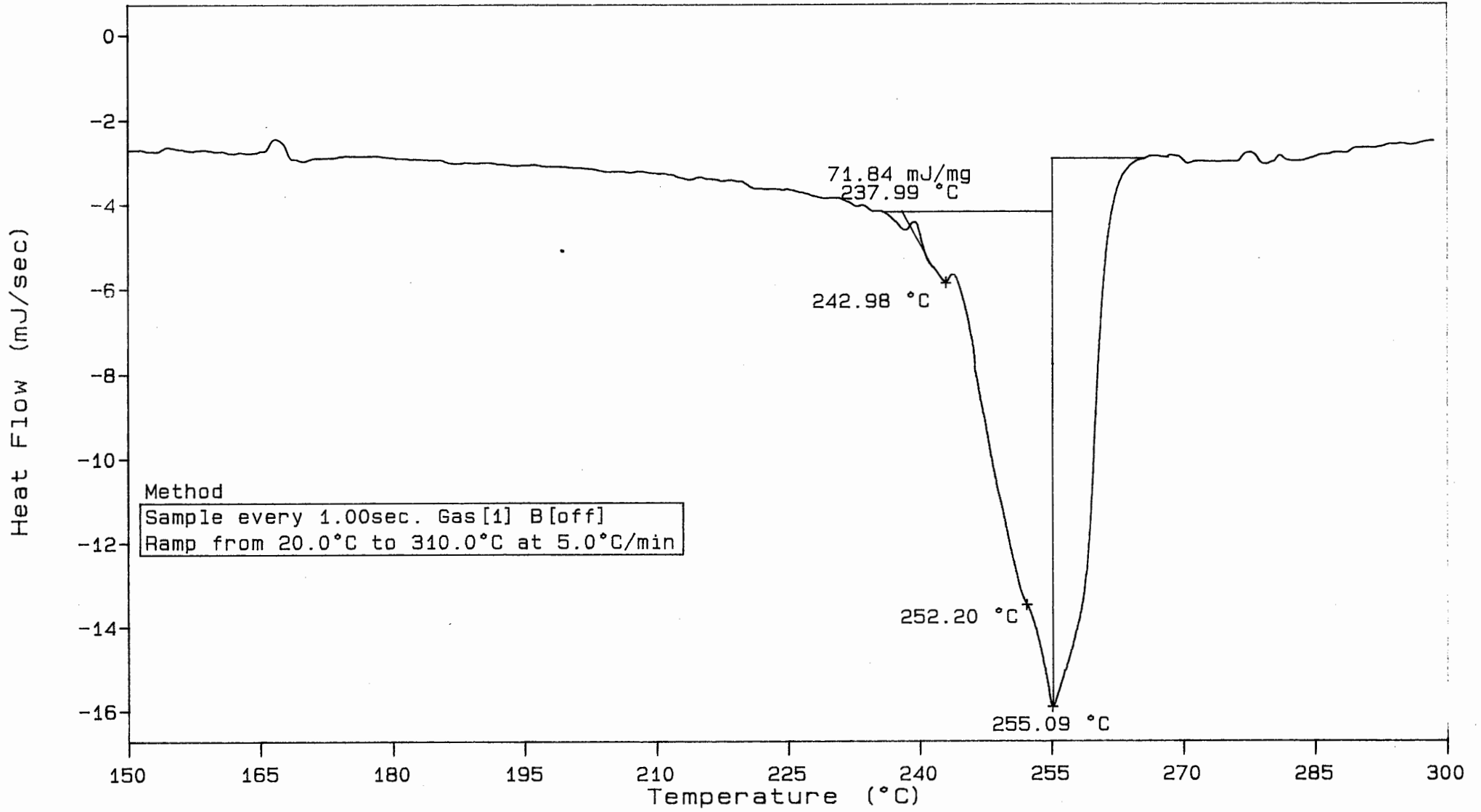

ARGR.92.091

- 7 -

Confidential

VERSION: V5.12

Figure 2 DSC melting curve of E-type Carilon

DSC (PL)

SAMPLE : Carilon  
RUN ID : 08.05.92  
SIZE : 6.600 mg  
OPERATOR: C. van Gaans

DATE RUN: May/08/1992  
GAS 1 : N2  
GAS 2 :  
COMMENT : EP-type Tm=230

Billiton Research BV

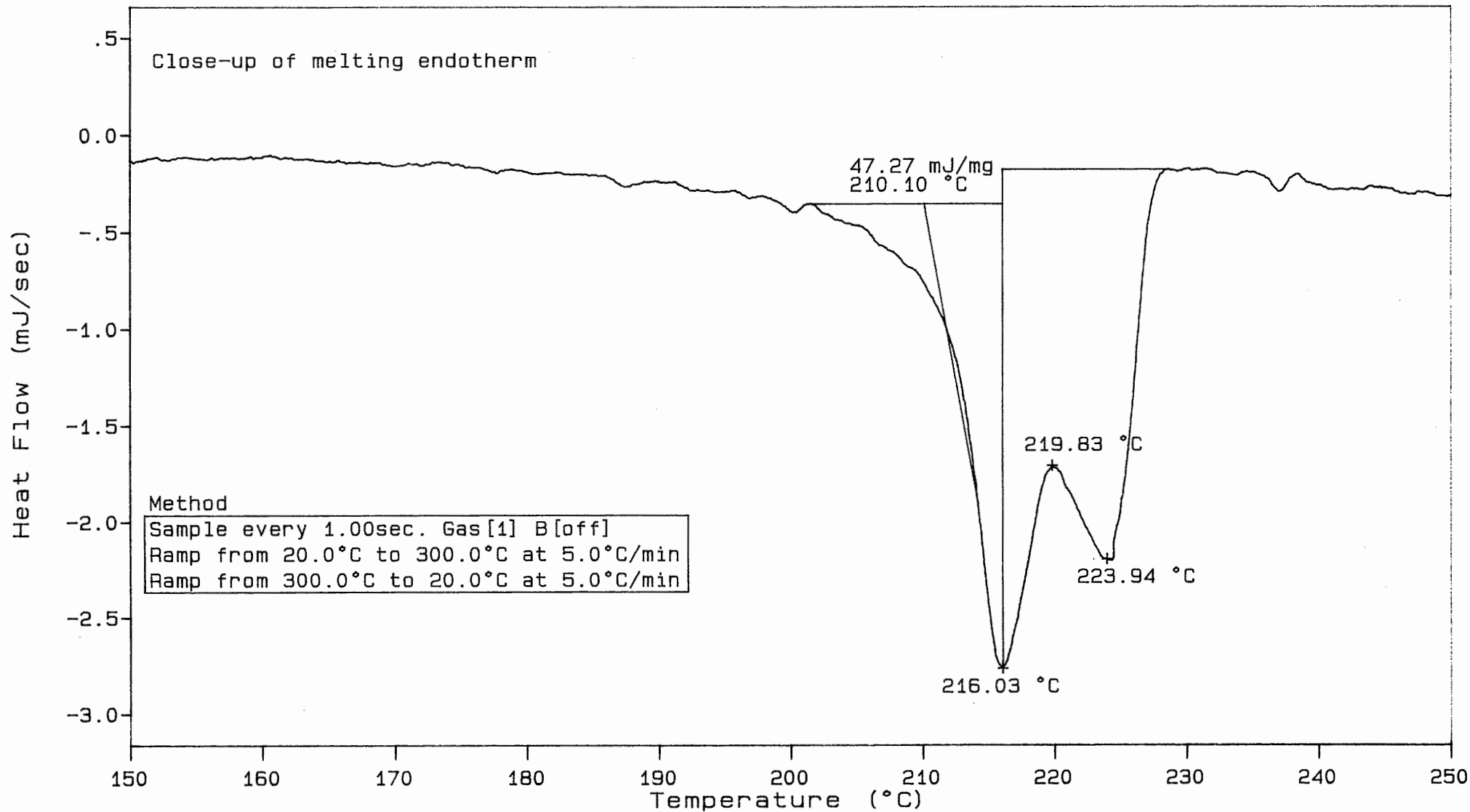

ARGR.92.091

- 8 -

Confidential

VERSION: V5.12

Figure 3 DSC melting curve of EP-type Carilon

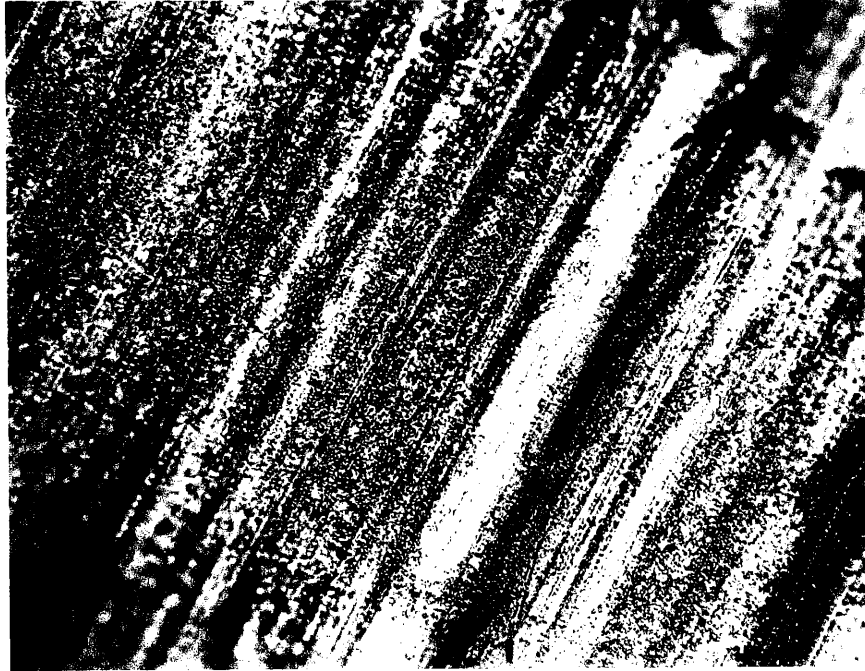

*Core-section of E-type Carilon Magnification  $200 \times 1 \text{ cm} \approx \mu\text{m}$ . Spherulites are seen as blue spots, matrix is yellow*

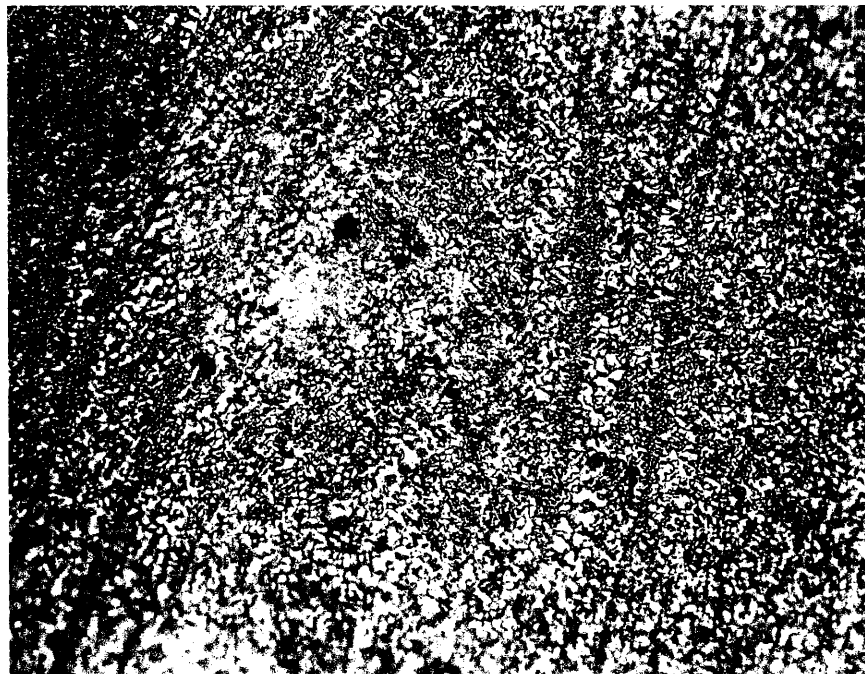

*Core-section of EP-type Carilon. Magnification is  $200 \times 1 \text{ cm} \approx 50 \mu\text{m}$ . Spherulites are blue, matrix is yellow. Flow pattern derived from injection moulding is seen as a solid structure.*

**Figure 4** Typical photomicrographs of Carilon E- and EP-types

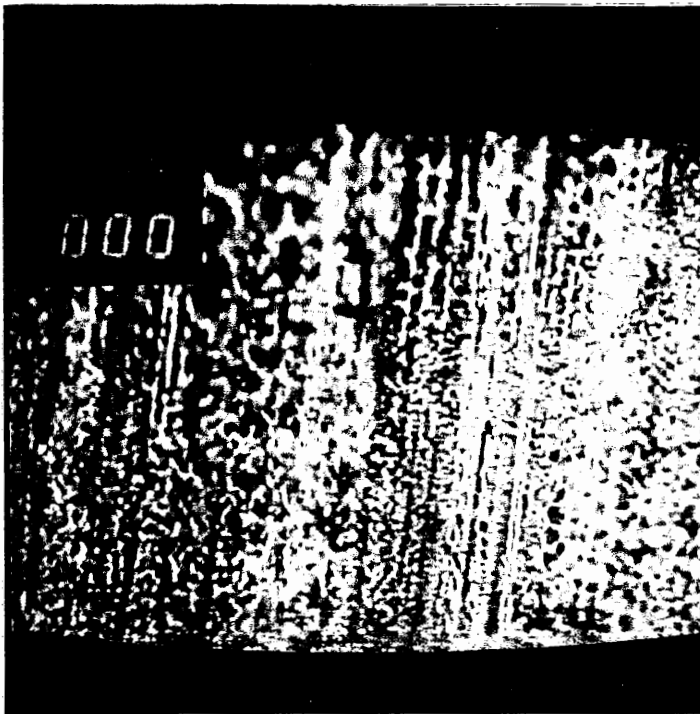

(a) Starting situation  
Magnification is 1000 times

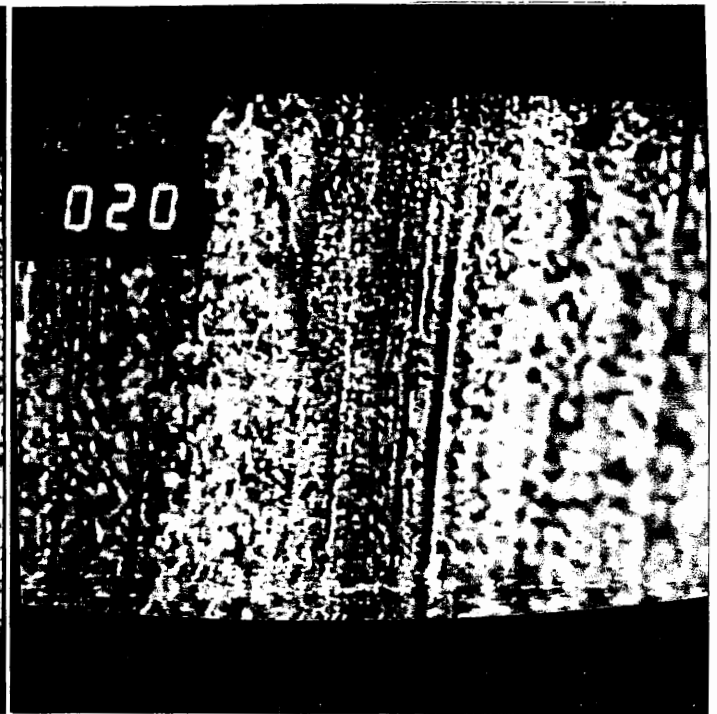

(b) Situation after electrical power  
has been switched on

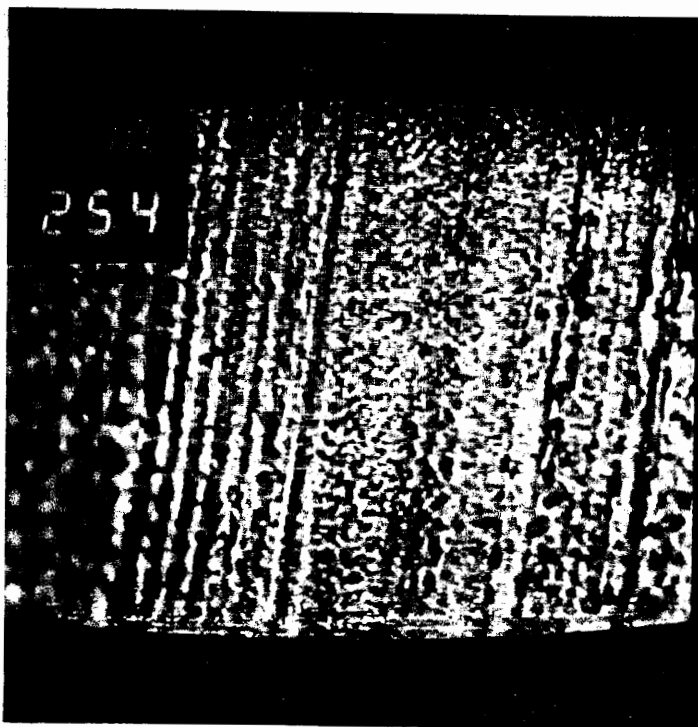

(c) First stage of melting

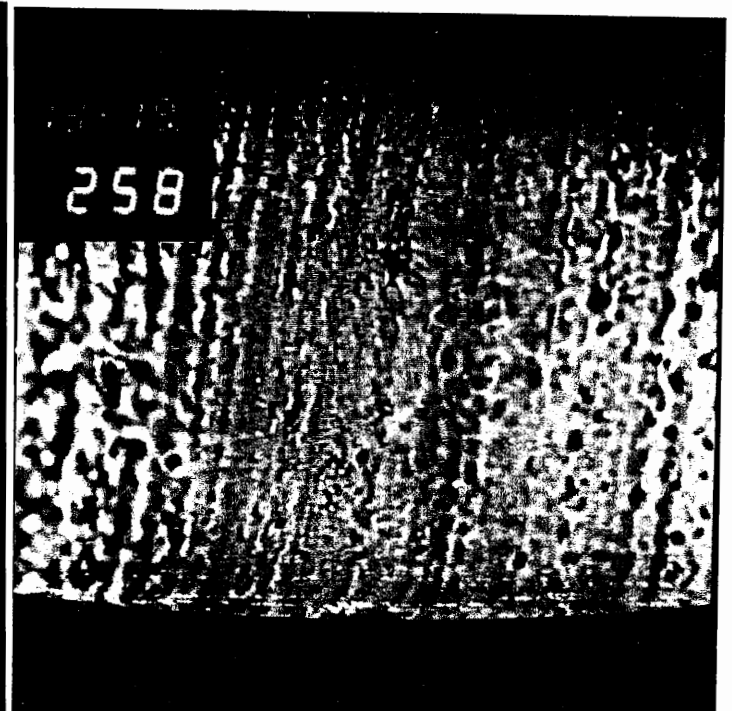

(d) Second stage of melting

Figure 5 Video images of the melting behaviour of E-type Carilon

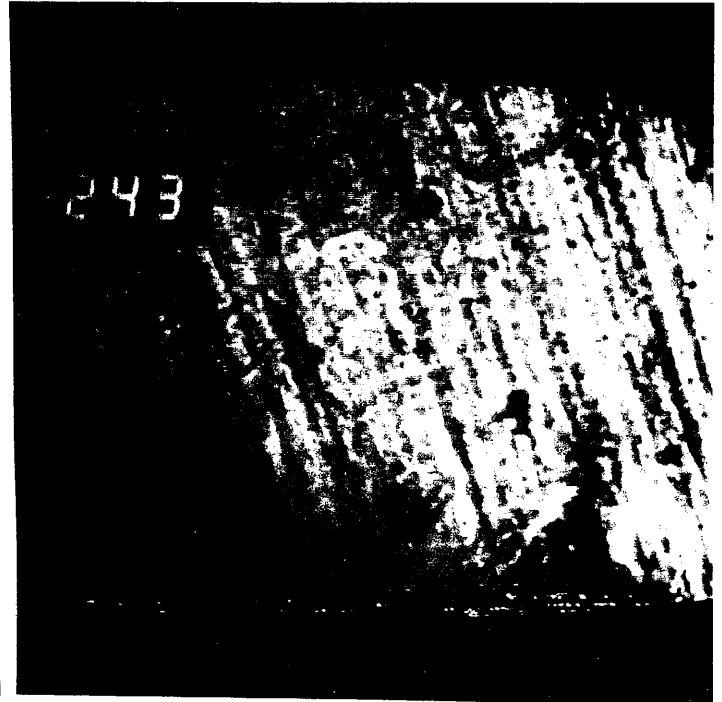
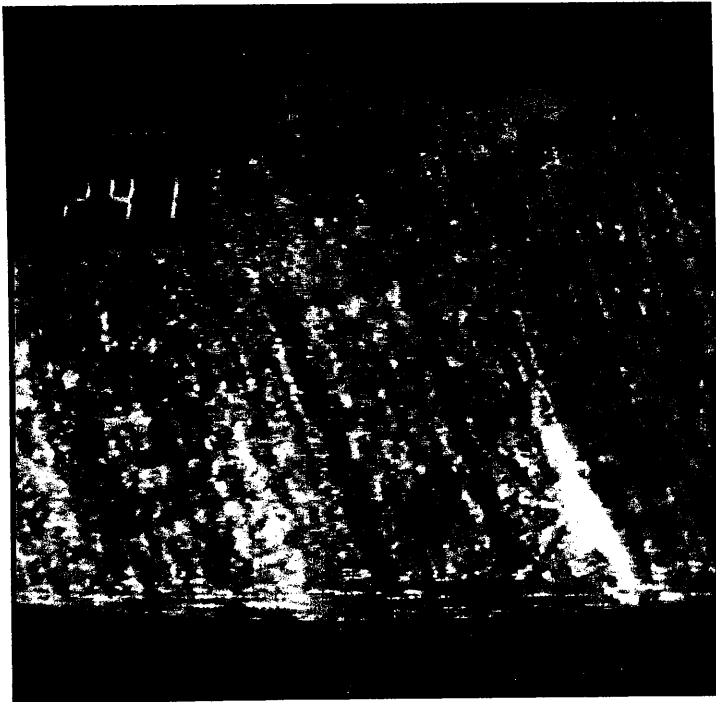

(a) Onset of melting of core section of E-type Carilon  
Magnification 1000 times

(b) First stage of melting

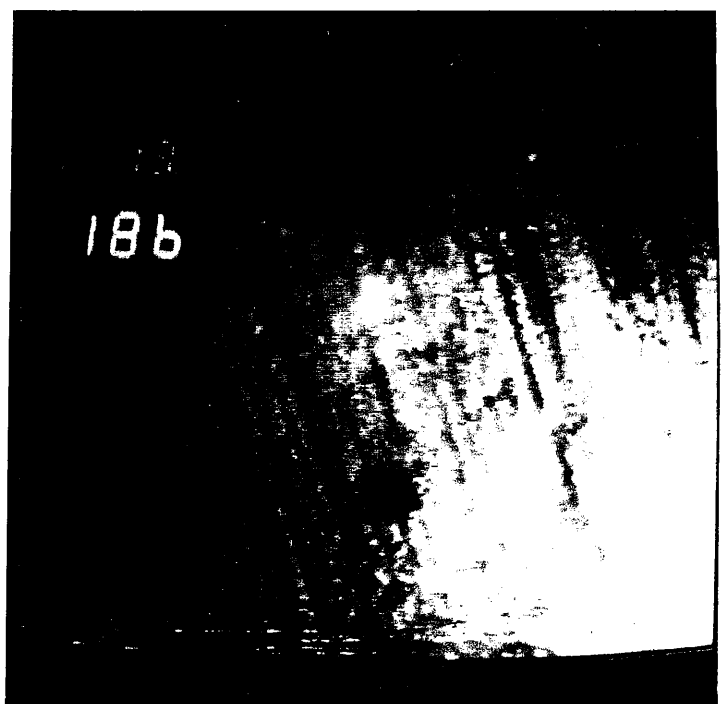
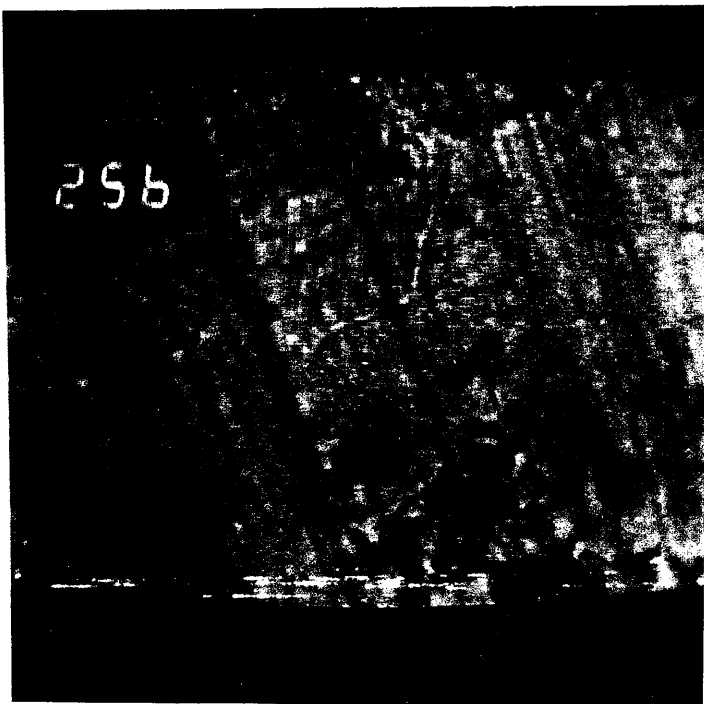

(c) Second stage of melting

(d) First stage of crystallisation

Figure 6 Video images of melting and crystallisation of E-type Carilon



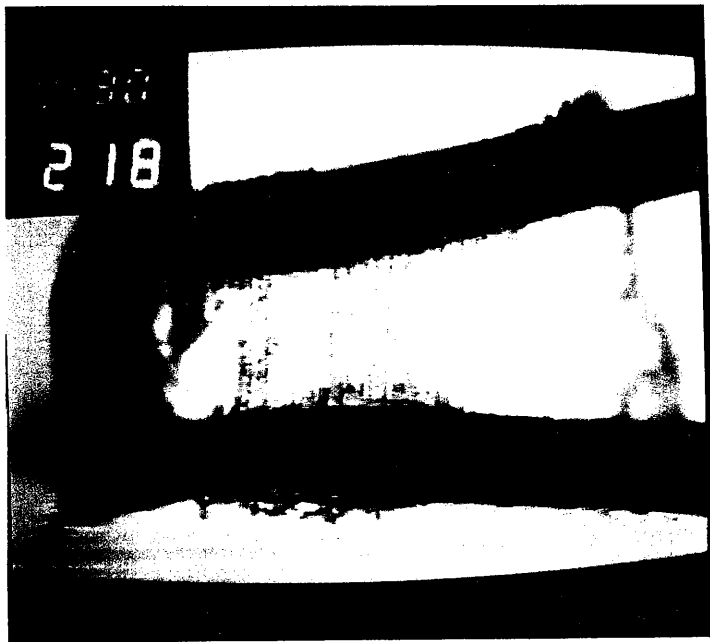

(a) Onset of melting starting at lower limb of thermocouple. Magnification 60 times

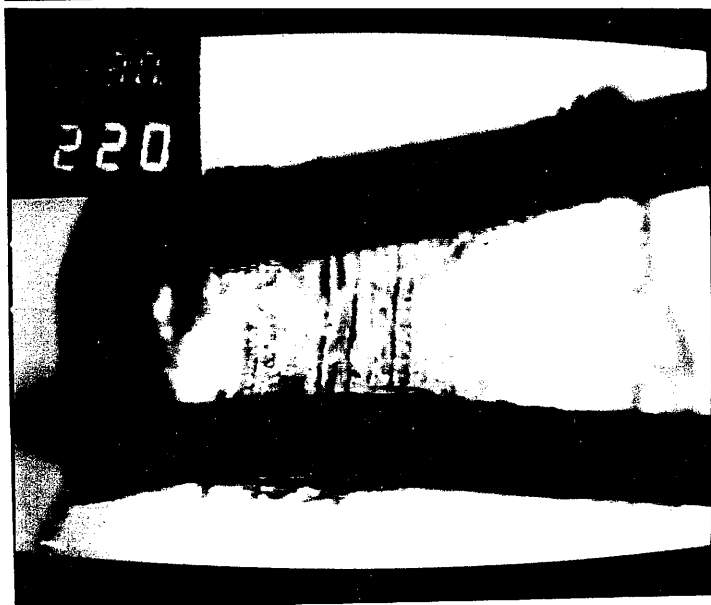

(b) Progress of molten area (purplish-red)

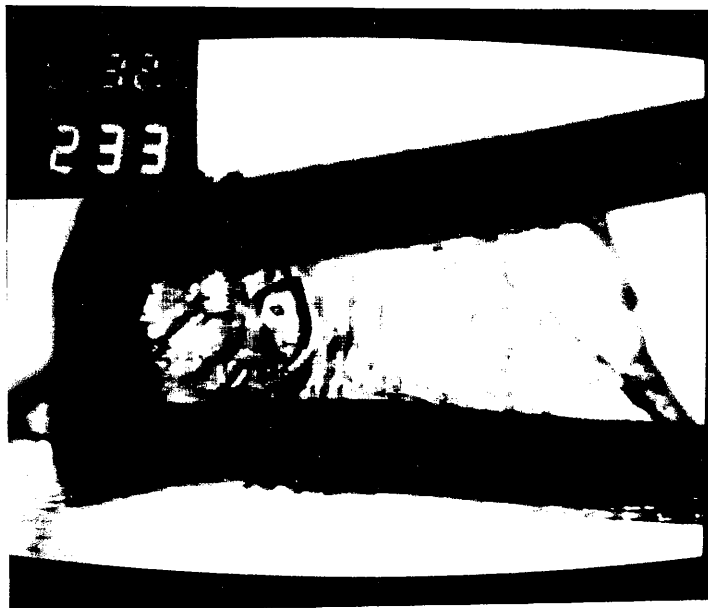

(c) Progress of molten area

Figure 7 Video images of melting of EP-type Carilon

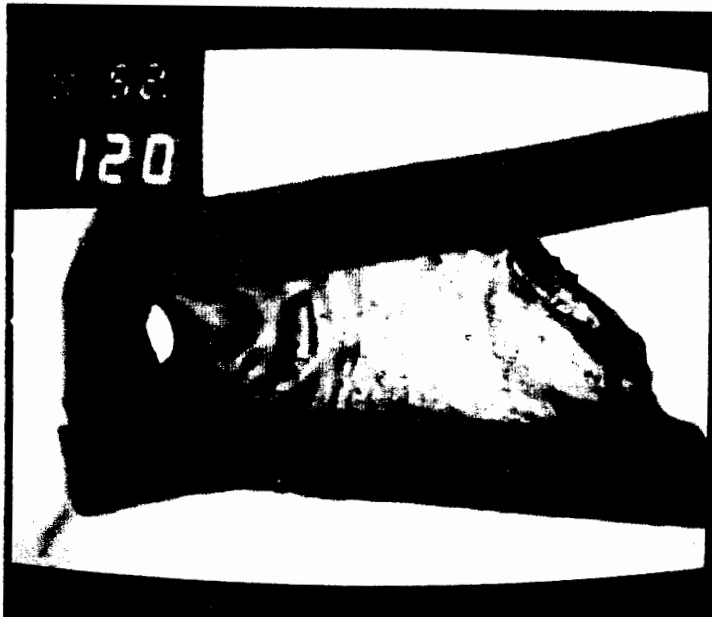

(a) *Onset of crystallisation (seen as a yellow coloration)*  
*Magnification in 60 times*

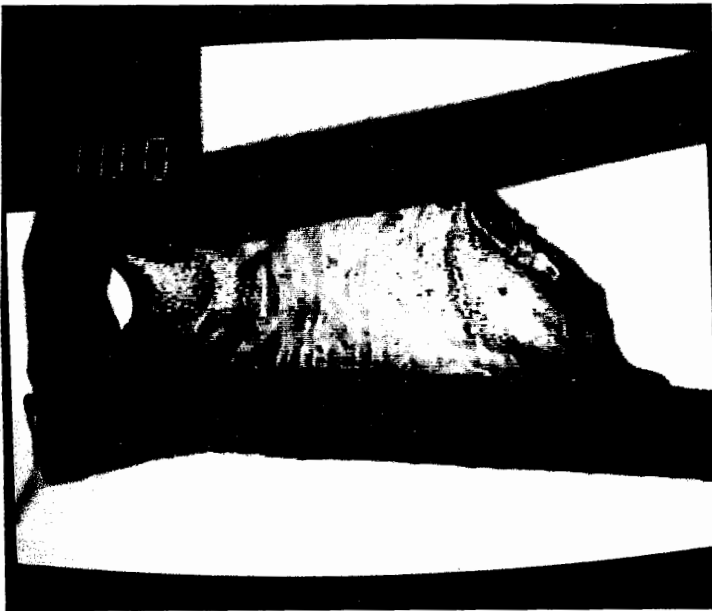

(b) *Progress of crystallisation*

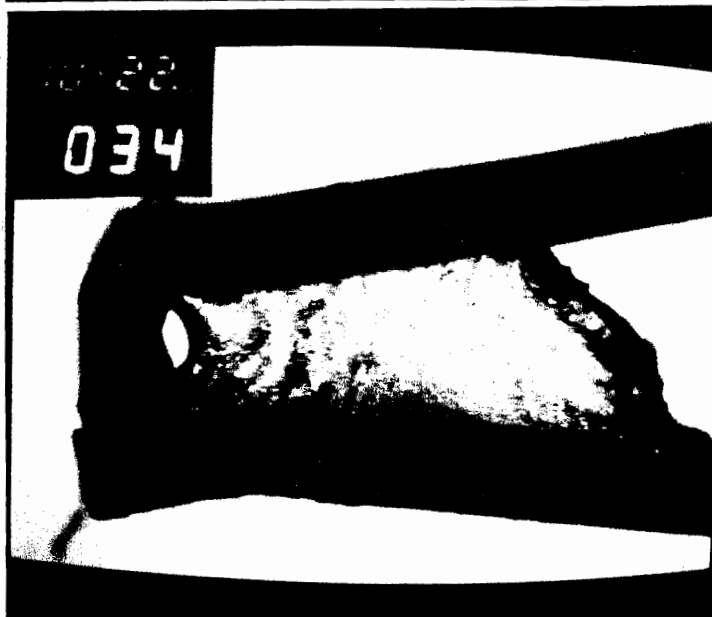

(c) *Progress of crystallisation*

**Figure 8** *Video images of crystallisation of EP-type Carilon*

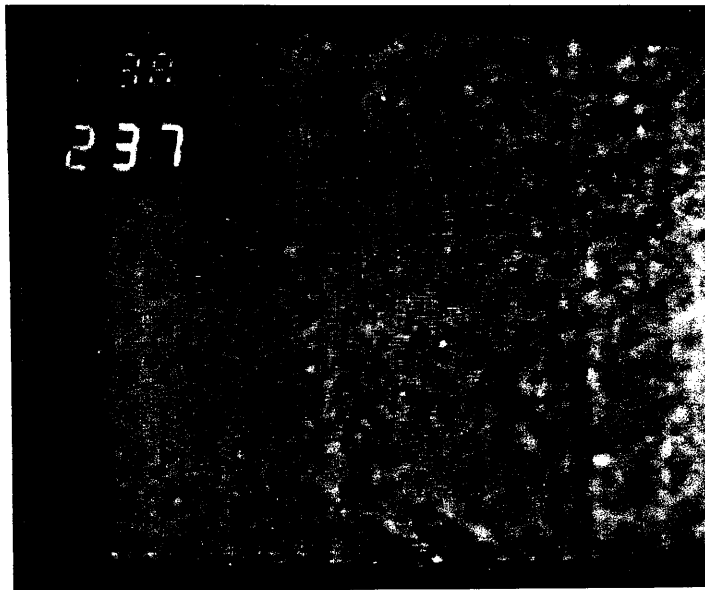

(a) *Apparent onset of crystallisation. Blue colours suggest that remnants of Spherulites are still present in the melts. Magnification 1000 times*

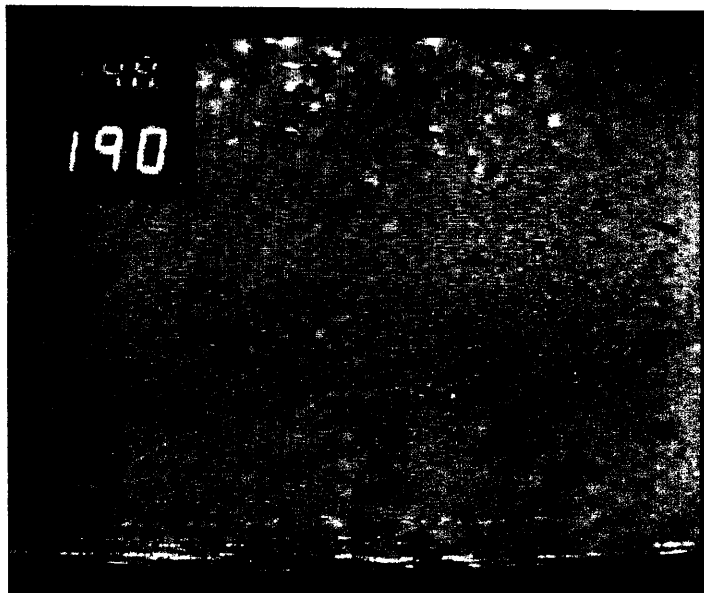

(b) *Distinct onset of crystallisation. Blue coloured spherulites are visible in top of image.*



(c) *Progress of crystallisation.*

**Figure 9** *Video images of crystallisation of EP-type Carilon in close-up*



(d) Progress of crystallisation

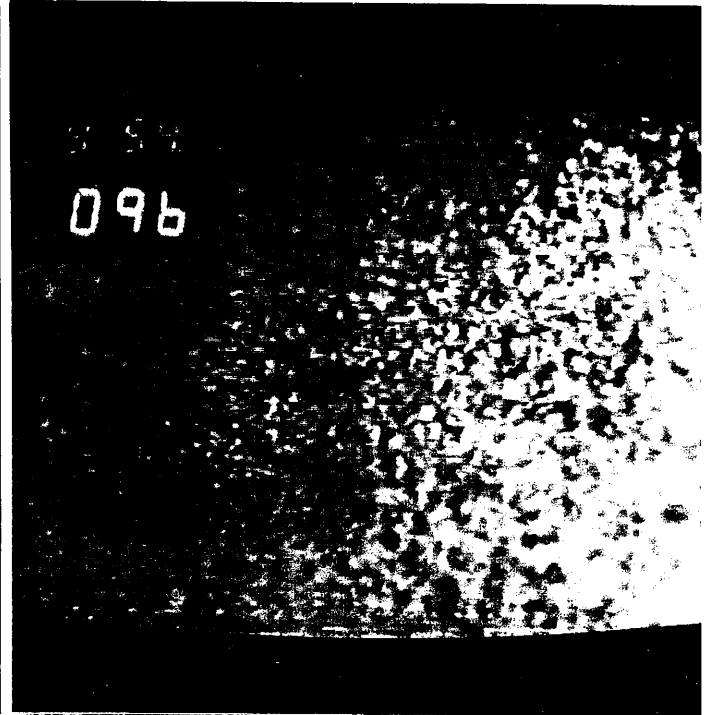

(e) Progress of crystallisation

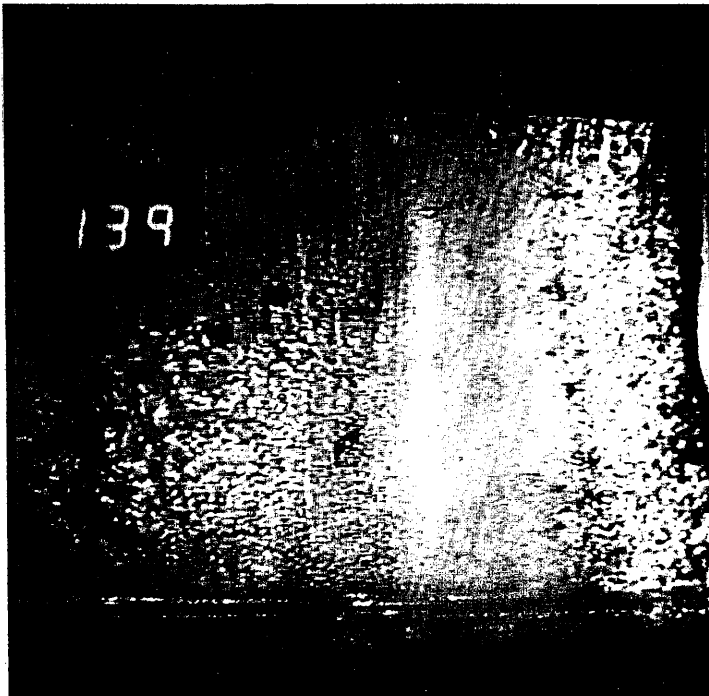

(f) Progress of crystallisation in rim section of specimen showing a blue deformation band



(g) Progress crystallisation in area shown also in (f) Note significant difference in spherulites size between deformation band and adjacent areas

Figure 9 (Cont'd)

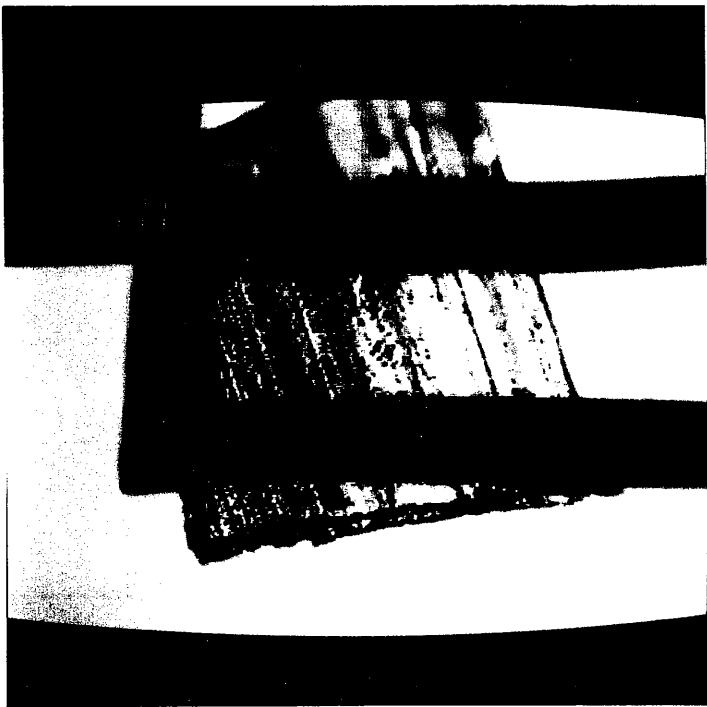

(a) E-type of room temperature  
Magnification 60 times

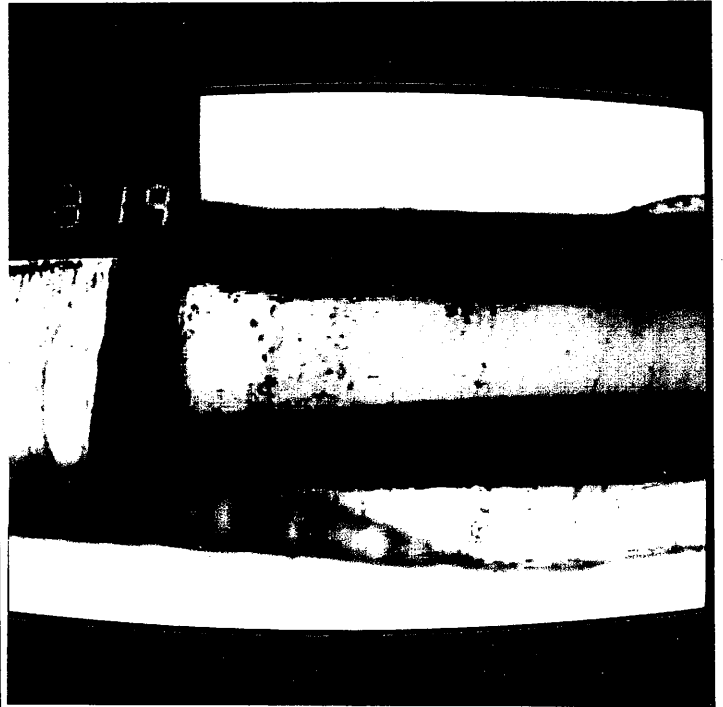

(b) E-type above the melting point  
(different specimen as shown in (a))

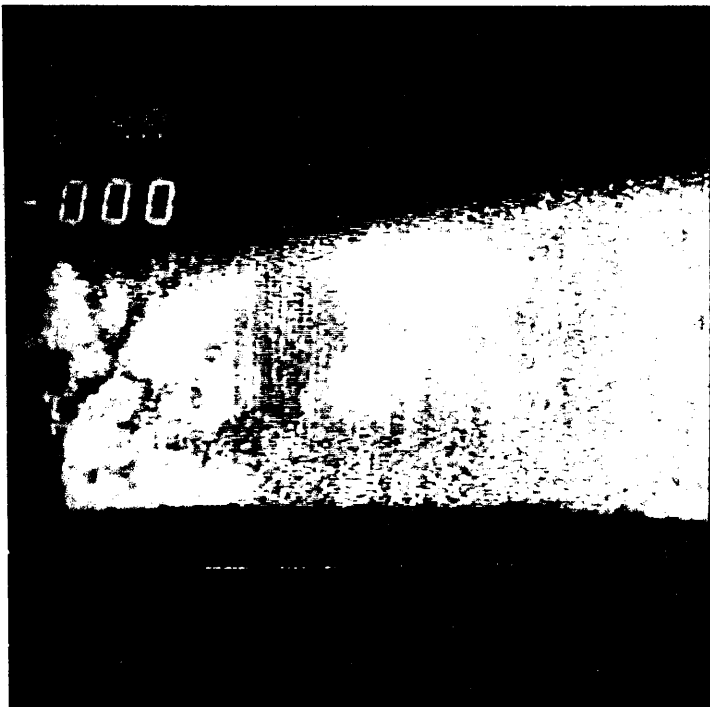

(c) EP-type at room temperature



(d) EP-type above the melting point  
(some specimen as shown in (c))

**Figure 10**

Rheology of microtomed sections of E- and EP-type Carilon above the melting point

## Distribution

<b>Central Offices, The Hague</b>	
SICM - CMFS/234	5
<b>Central Offices, London</b>	
SIPC - ODLC/731	3
SIPC - CBDR/31	1
<b>Shell Research B.V.</b>	
KSLA, Amsterdam - IDC/13	2
KSLA, Amsterdam - AG/12, PRP (via IDC/13)	2
<b>N.V. Shell Research S.A.</b>	
CRCSL - Louvaine-la-Neuve	1
CRCSL - PT/PK	1
<b>Shell Canada Ltd.</b>	
Calgary Research Centre - RTAD/1	1
<b>Shell Nederland Chemie B.V., Rotterdam</b>	
SNC	1
<b>Billiton Research B.V., Arnhem</b>	
AN/11	1
BR/1/10/20	1
ICS/3	4

<p>Research not shared with Shell Oil Company USA. Not to be sent to Shell Oil Co.</p>
--

<p><b>Date of Issue</b></p>
-----------------------------

<p>2 February 1994</p>
------------------------